

1991

FORD MUSTANG



MUSTANG GT

You certainly don't have to be a professional driver or performance enthusiast to enjoy Mustang GT. The only prerequisite is an appreciation for the fun of driving.

One look at the ground effects styling tells you this car was not designed with basic transportation in mind. The 5.0L HO engine is among the most powerful production engines in America, generating 225 horsepower and 300 lb. ft. of torque. These are reassuring numbers indeed for situations like passing when extra power translates into extra confidence.

And GT is equipped to handle the most tortuous pavement with a wide, aggressive stance, 16-inch cast aluminum wheels, 55ZR performance tires and a performance suspension which includes Ford's quadra-shock setup in the rear and a progressive-rate spring at each corner.

With this kind of performance hardware, you would expect to find an interior equipped with comfortable, multi-adjustable articulated front bucket seats. Full instrumentation with "user friendly" analog gauges. A 7,000 rpm tachometer for more efficient shifts with the 5-speed. They're all there.

After more than a quarter century, Mustang GT offers few surprises. You get a contemporary, bold look. Legendary spirit. And a large order of motoring fun.

The Mustang GT hatchback is shown above in Bright Red. For those with a weakness for sunny days and starry nights, the transportation of choice is the Mustang GT convertible, shown here in Ultra Blue Clearcoat Metallic.





5.0

Mustang 5.0 is a true
muscle car. It's got
the power, the speed,
the handling, the look.
It's a real winner.

Mustang 5.0 is a true
muscle car. It's got
the power, the speed,
the handling, the look.
It's a real winner.

MUSTANG LX 5.0L

The Mustang LX 5.0L offers you a choice of hatchback, 2-door sedan or convertible bodystyles, all with the performance of the GT, but with the smooth styling of the LX.

You have the same GT-type interior including full instrumentation, electronic AM/FM stereo and front bucket seats with adjustable seat cushion side bolsters, under-thigh support and power lumbar support. The brake and accelerator pedals are positioned to facilitate heel-and-toe downshifting.

LX 5.0L models also come with all the performance level equipment of the GT. Under the hood is the powerful 5.0L HO V-8 with sequential multiple-port electronic fuel-injection which puts out 225 horsepower and 300 pound feet of torque.

Mustang LX 5.0L 2-door hatchback, shown below in Black, combines smooth styling with the performance of the GT.



The LX 5.0L 2-door sedan, one of three bodystyles, is shown at right in Titanium Frost Clearcoat Metallic.



The suspension system uses nitrogen gas-pressurized hydraulic front struts, rear Quadra-shock set-up for that taut performance ride and progressive rate coil springs at all four corners.

The wheels are 5-spoke 16-inch cast aluminum, but with slightly different all-season performance radials. And there's the same quick ratio power steering and 5-speed Borg Warner transmission.

Convertible models are a big part of the Mustang mystique. Just imagine all the fun you can have in a car with this much pizzazz. Now think about how much fun you can have with the top down.

The convertible top is power retractable with a glass rear window. The front side windows and the rear quarter windows are also conveniently power operated.





*The LX 5.0L convertible
is shown above in
Medium Red.*

MUSTANG LX

The standard LX, featured on these two pages, is a perfect example of the Mustang credo. Provide a lot of value, a lot of driver satisfaction and a whole lot of fun.

Mustang LX is powered by a responsive 2.3 liter overhead cam 4-cylinder engine with eight spark plugs. This advanced powerplant uses two plugs per cylinder, computer-designed intake ports and tuned air intake runners to provide high combustion efficiency. The standard 5-speed manual transmission (fifth gear overdrive), adds to the responsiveness and fun.

The LX suspension system utilizes nitrogen gas-pressurized hydraulic struts and a stabilizer bar in front along with nitrogen gas-pressurized hydraulic shocks in the rear. Power rack-and-pinion steering and power brakes are also standard fare.

And LX is well equipped, too. Inside are reclining low back bucket seats and center console. Also standard is full analog instrumentation along with an electronic AM/FM stereo search radio with four speakers.

Versatile Mustang hatchback models feature a split fold rear seat and fully carpeted cargo area with 30 cubic feet of space (both seat backs folded down) and a window shade-type cover.

To make any Mustang LX even more appealing, order Preferred Equipment Package 240A. It includes these desirable equipment items: power side windows, dual electric mirrors, power door locks, power decklid/liftgate release, electronic AM/FM stereo radio with cassette tape player, speed control, cargo tie-down net, styled road wheels and front floor mats.

The LX convertible, shown here in Oxford White, is just one example of the freedom you can experience in a Mustang (the wheels shown are subject to late availability. See your dealer).



The LX hatchback, shown here in Light Crystal Blue Clearcoat Metallic, combines versatility and value in a way only Mustang can.





*Mustang LX 2-door
sedan, shown here in
Medium Titanium, proves
you don't have to spend a
lot to get a lot.*

MUSTANG INTERIOR

Mustang's sporty interior plays a major role in instilling the fun, confident feeling you get when behind the wheel. Passenger comfort, too, is well attended to.

Mustang's front bucket seats are designed to be firm and supportive to help reduce fatigue. High density foam pads in the seat cushion and seat back side bolsters help hold you in place. The front seat backs recline so you can drive in the position that's right for you.

In the performance-oriented LX 5.0L and GT models, the articulated front bucket seats include adjustable seat cushion side bolsters and a power adjustable lumbar support. There's also an adjustable underthigh support.

The rear bench seat provides room for two and in hatchback models it has a split-fold design that provides a more versatile

cargo area for all kinds of stowables.

When you get behind the wheel of Mustang you're treated to a clear view of easy to read analog gauges. And there is a full complement: fuel, engine coolant temperature, voltmeter, oil pressure and tachometer. There are also alert lights for "check oil," "low coolant" and "low fuel."

The optional speed control switches are set in the steering wheel spokes at your fingertips. Climate control switches are rotary-designed to ease operation. Switches for running lights, emergency flasher and the optional rear defroster are positioned high and directly in front of the driver so they are easy to reach and in clear view. The turn signal lever also controls the interval wiper/washer, high beam and flash-to-pass features.

The standard AM/FM stereo radio is

electronically tuned and features four-speaker sound. Or, order the electronic AM/FM stereo with cassette tape player. Select the optional Premium Sound and get 80-watts of additional power and six-speaker sound.

Both the left and right rearview mirrors are remote controlled. In convertibles, the mirrors are electrically remote controlled.

Included as standard equipment on all Mustang models is a driver's side air bag supplemental restraint system, which is intended for use in conjunction with the lap/shoulder safety belt. The air bag is concealed and located in a module in the center of the steering wheel. It is designed to deploy in the event of a frontal impact roughly equivalent to, or more severe than, striking a similar-sized parked car at a 28 mile per hour rate of speed.

Mustang's instrument panel is a lesson in ergonomics. Important controls are placed within easy reach.



The LX front bucket seats are firm and supportive to help reduce fatigue.



The articulated front bucket seats are standard in GT and LX 5.0L.



Mustang's standard driver's side air bag SRS is intended to supplement, not replace, lap/shoulder belts, which should always be worn.

MUSTANG POWER

The 5.0L High Output V-8 that powers Mustang GT and LX 5.0L, with a rating of 225 horsepower at 4,200 rpm, is among the most powerful production engines in America. Perhaps even more significant is the amount of torque available at the low end. 300 lb. ft. at only 3,200 rpm.

But, there's more to consider than just power and torque. There's the track record of an engine design that has proven its mettle. Advanced features such as sequential electronically controlled multiple-port fuel injection. And a wealth of high-performance equipment like forged steel connecting rods for strength. Proven overhead valve design with modified combustion chambers. Cast iron block and heads and aluminum intake manifold. Roller tappets help reduce friction and heat. And a double roller timing chain helps keep everything working together efficiently.

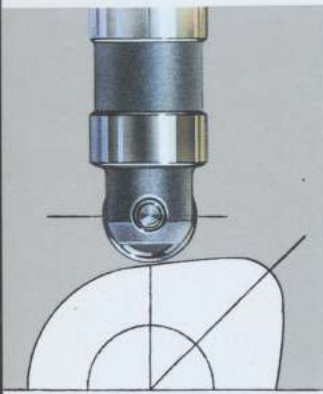

The 5.0 engine has the components to deliver high performance. One example is the roller tappets that help reduce friction and heat.

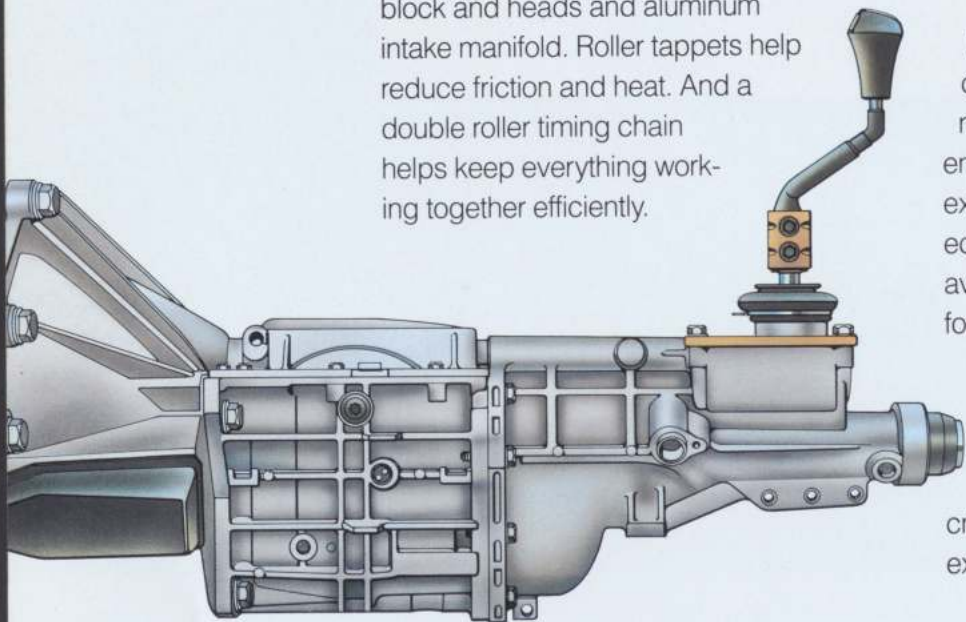

Other high-performance components include induction-hardened camshaft; forged aluminum alloy pistons; tuned stainless steel tubular headers; large diameter dual exhausts and much more.

A standard 5-speed manual transmission with overdrive fifth gear lets you put all that power to work with the precision of direct linkage shifting. Gear ratios for the Mustang 5-speed are: 1st gear — 3.35; 2nd gear — 1.99; 3rd gear — 1.33; 4th gear — 1.00; 5th gear — 0.68.

The 2.3L 4-cylinder engine that powers LX models is new to Mustang for 1991. This advanced powerplant utilizes eight spark plugs — two per cylinder. With two plugs per cylinder, tuned air intake runners and computer-designed intake ports, the engine delivers high combustion efficiency. Combined with multi-port fuel injection and electronic engine control, the 2.3L delivers an excellent balance of response and fuel economy. (EPA mileage ratings were not available when this catalog was approved for publication. See your dealer for the latest information about gas mileage). With Mustang, you choose the level of performance that suits you, from a comfortable cruise or commute all the way to the exhilaration that comes with 225 horses.



Mustang's 5.0L engine has a proven overhead valve design with modified combustion chambers. It uses forged aluminum alloy pistons for light weight and good heat dissipation.



MUSTANG FEATURES

Whether you like Mustang for its performance, its contemporary style, or the flair of its wide open spirit, you will surely appreciate the extra-value features found in your favorite Mustang.

Extra-value features are what help set Mustang apart from the rest of the crowd. They add to the appearance and make Mustang more comfortable and versatile.

Examples are the driver's side air bag supplemental restraint system, the rear lap/shoulder belts, and the cargo area cover in the hatchbacks.

And these features are all standard equipment items, which is why they represent extra value, not extra cost.

The center console that divides the front passenger/driver compartment is a helpful companion on the road. It provides storage for cassette tapes, coins, sunglasses, etc. and includes a fold down armrest. The parking brake is cleverly recessed and integrated into the design.





Mustang offers you the advantages of full analog instrumentation. Included are gauges for coolant temperature, oil pressure, charging system voltmeter, fuel gauge and a 7,000 rpm tachometer (6,000 in LX 2.3L models). For extra measure, Mustang also offers alert lights for "Check Oil," "Low Coolant," "Low Fuel," and "Low Washer Fluid."

Cast aluminum 5-spoke, 16-inch wheels help give Mustang GT and LX 5.0L models their lean good looks.

One of the reasons people buy hatchback models is because of the versatility offered in the area behind the front seats. Mustang hatchbacks add to that versatility with a practical 50/50 split-fold rear seat.

The optional cargo net is just the thing for keeping all your eggs in one basket. It holds your groceries in one spot. And in hatchback models helps contain loose objects in the cargo area.

The convertible benefits from an appearance improvement for 1991. Compared with last year's model, the top, when retracted, sits much lower, enhancing the sleek top-down profile.

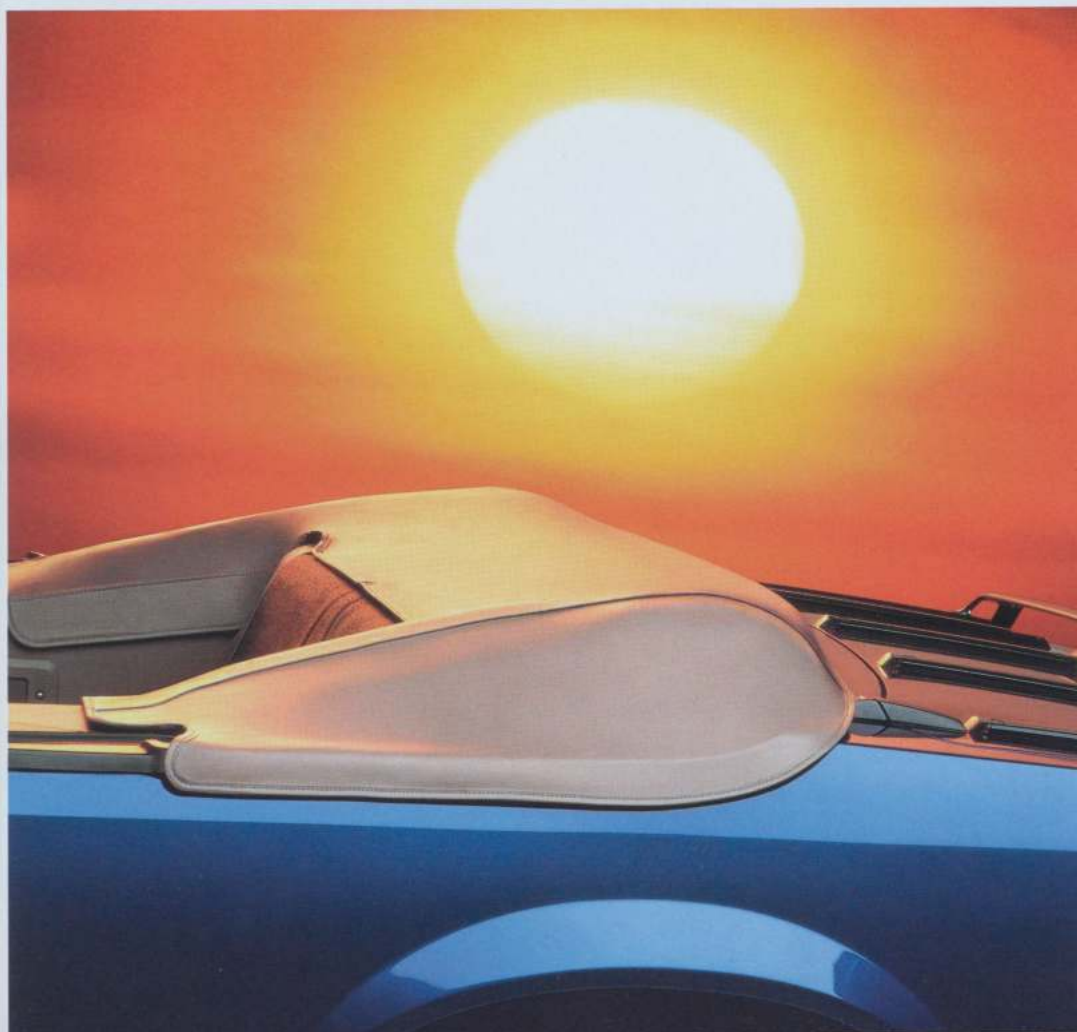

FEATURES, OPTIONS AND PREFERRED EQUIPMENT PACKAGES



- A. Electronic AM/FM stereo radio with cassette tape player
 B. 7-band graphic equalizer
 C. Flip-up open-air roof for hatchback models
 D. Rear window defroster
 E. Left to right: Stamped steel wheel; wire-style wheel cover; styled road wheel; cast aluminum wheel; 5-spoke cast aluminum wheel

COLORS AND TRIMS

MUSTANG LX and LX SPORT

Exterior Paint Colors

Interior Trim Colors

	Titanium	Crystal Blue	Scarlet Red	Black	Convertible only White/Titanium	Convertible only White/Red
Medium Red	X		X	X		X
Bright Red	X		X	X		X
Oxford White	X	X	X	X	X	X
Wild Strawberry Clearcoat Metallic	X		X	X	X	X
Light Crystal Blue Clearcoat Metallic		X		X		
Twilight Blue Clearcoat Metallic	X	X				
Deep Emerald Green Clearcoat Metallic	X				X	
Black Clearcoat (non-metallic)	X		X	X	X	X
Medium Titanium Clearcoat Metallic	X		X	X	X	
Titanium Frost Clearcoat Metallic	X	X	X	X	X	
MUSTANG GT						
Medium Red	X		X	X		X
Bright Red	X		X	X		X
Oxford White	X		X	X	X	X
Black Clearcoat (non-metallic)	X		X	X	X	X
MUSTANG GT WITH TITANIUM LOWER ACCENT TREATMENT						
Wild Strawberry Clearcoat Metallic	X		X	X	X	X
Ultra Blue Clearcoat Metallic	X			X		
Twilight Blue Clearcoat Metallic	X					
Deep Emerald Green Clearcoat Metallic	X				X	
Medium Titanium Clearcoat Metallic	X		X	X	X	X
Titanium Frost Clearcoat Metallic	X		X	X	X	X

SPECIFICATIONS

MUSTANG GT AND LX 5.0L

Engine type	5.0L overhead valve V-8
Induction system	Electronic sequential multiple-port fuel injection
Transmission	Standard 5-speed manual overdrive. Optional automatic overdrive
Suspension, front	Modified MacPherson, nitrogen gas-pressurized hydraulic struts, variable rate coil springs, 1.3-inch stabilizer bar
Suspension, rear	Variable rate coil springs, Quadra-Shock with vertically-mounted nitrogen gas-pressurized shocks, horizontally-mounted hydraulic with freon-filled bag axle dampers, .79-inch stabilizer bar
Steering	Power rack-and-pinion, 14.7:1 on-center ratio
Brakes	Power front disc/rear drum
Wheels	16x7-inch 5-spoke cast aluminum
Tires	P225/55ZR16 BSW performance radials

MUSTANG LX

Engine type	2.3L OHC twin-plug 4-cylinder
Induction system	Electronic multiple-port fuel injection
Transmission	Standard 5-speed manual overdrive. Optional automatic overdrive
Suspension, front	Modified MacPherson, nitrogen gas-pressurized hydraulic struts, coil springs, stabilizer bar
Suspension, rear	Four-bar link, nitrogen gas-pressurized hydraulic shocks, coil springs
Steering	Power rack-and-pinion, 14.7:1 on center ratio
Brakes	Power front disc/rear drum
Wheels	Stamped steel, 14 x 5 inch
Tires	P195/75R14 BSW steel-belted radials

PREFERRED EQUIPMENT PACKAGES

Note: Package content is subject to change.			
S=Standard O=Optional X=Included in package	LX 240A	LX 5.0L 245A	GT 249A
Power Equipment Group (1) Includes: Power Lock Group with door locks and remote trunk/hatch release, dual electric remote control mirrors, power side windows	X	X	X
Cargo tie down net	X	X	X
Front floor mats	X	X	X
Speed control	X	X	X
Electronic AM/FM stereo radio with cassette player and integral digital clock	X	X	X
Styled road wheels (2)	X		
Premium Sound System Includes 6 speakers and a four channel amplifier that increases power to 80 watts	O	X	X
Custom Equipment Group Includes: air conditioning and dual illuminated visor mirrors (2)	O	X	X
2.3L twin-plugs EFI engine/5-speed manual transmission	S		
2.3L twin-plugs EFI engine/automatic overdrive transmission	O		
5.0L HO EFI engine/5-speed manual transmission		S	S
5.0L HO EFI engine/automatic overdrive transmission		O	O
P195/75R14 BSW	S		
P225/55ZR16 BSW All season performance tires		S	O
P225/55ZR16 BSW performance tires		O	S
Cloth low back bucket seats	S		
Vinyl low back bucket seats	O	O	
Cloth and vinyl articulated sport seats		S	S
Leather articulated sport seats		O	O
Rear window defroster	O	O	O
Clearcoat paint	O	O	O
Flip-up open-air roof (hatchbacks only)	O	O	O
Graphic equalizer	O	O	O
Radio credit option (3)	O	O	O
Titanium lower accent bodyside treatment (4)			O
Cast aluminum wheels and P205/65R x 15 BSW tires	O		
Wire style wheel covers	O		

(1) Standard on convertible. (2) Wire style wheel covers may be substituted without loss of discount. (3) No radio installed. (4) Available with selected GT colors, see Colors and Trims on page 14.

MEASUREMENTS

	2-Door Sedan	2-Door Hatchback	Convertible
Wheelbase	100.5"	100.5"	100.5"
Length	179.6"	179.6"	179.6"
Height	52.1"	52.1"	52.1"
Width	68.3"	68.3"	68.3"
Front tread	56.6"(1)	56.6"(1)	56.6"
Rear tread	57.0"	57.0"	57.0"
Trunk or cargo volume (cu. ft.)	10.0	30.0(2)	6.4
Passenger capacity	4	4	4

(1) 57.9 on GT. (2) 12.2 cu. ft. with rear seat backs up.

MAJOR STANDARD FEATURES

Exterior

- Flush, aerodynamic halogen headlamps
- Urethane lower bodyside protection
- Black bodyside protection moldings
- Flush quarter window glass (sedans and hatchbacks)
- Wraparound taillamps
- Dual remote control mirrors, RH convex (sedans and hatchbacks)
- Color coordinated bodyside paint stripe
- Single wing rear spoiler with integrated stop lamp (hatchbacks)
- Finned wheel covers
- 5-spoke cast aluminum wheels (GT and LX 5.0L)
- Ground effects styling (GT)
- Fog lamps (GT)

Interior

- Driver's side air bag supplemental restraint system (SRS)
- Rear passenger 3-point active lap/shoulder belt restraint system
- Front and rear ashtrays
- 16-oz. carpeting
- Cargo area cover (hatchbacks)
- Center console with armrest
- Cigarette lighter, front
- Clock, electronic (integral with radio)
- Driver's side foot rest/support
- Full instrumentation — tachometer, trip odometer, voltmeter, temperature, fuel and oil pressure gauges
- Alert lights for low oil check, low coolant, low fuel and low washer fluid (GT and LX 5.0L)
- Glove box, locking
- Light Group — Lamps in dome (integrated in mirror on convertibles) with door courtesy switches, lights in engine compartment, luggage or cargo compartment, glove box, front ashtray and headlamps "on" alert chime
- Pivoting header-mounted map light (hatchbacks)
- Dual visor mirrors with covers
- Split/fold-down rear seatbacks (hatchbacks)
- Stalk-mounted controls
- Low back reclining cloth front bucket seats with cloth headrests
- Articulated front sport seats, cloth trim, four-way headrests and power lumbar supports (GT and LX 5.0L)
- Full wrapover door trim panels with full length armrests and map pockets
- Side window demisters
- Tinted glass
- Electronic AM/FM stereo seek radio with integral digital clock and four speakers
- Interval wipers
- Luxury Sound Insulation Package

Convertibles

- Power retractable top with glass rear window
- Luggage rack with integrated stop lamp
- Power side and quarter windows

6-YEAR/100,000-MILE CORROSION PROTECTION

Mustang's corrosion warranty coverage for outer body panel rust-through is 6 years or 100,000 miles, whichever comes first. See your Ford Dealer for a copy of this limited warranty.



Participating Ford Dealers offer the Lifetime Service Guarantee, which guarantees their customer-paid work on your Ford vehicle for as long as you own it. A covered repair is paid for once. If it ever has to be fixed again, the repairing dealer will fix it free. Ask to see the Lifetime Service Guarantee when you visit your participating Ford Dealer.

Genuine Ford and Motorcraft original equipment replacement parts meet the same high standards as those installed in production.

OPTIONS AVAILABILITY

Options shown or described in this catalog are available at extra cost and may be offered only in combination with other options or subject to additional ordering requirements or limitations.



The leasing alternative is available to qualified lessees through your participating Ford Dealer, who can arrange a Red Carpet Lease® tailored to your circumstances through Ford Credit. A wide variety of financing plans are also available.

PRODUCT CHANGES

Ford Division reserves the right to change product specifications at any time without incurring obligations.

"ASK YOUR FORD DEALER"

Following publication of this catalog, certain changes in standard equipment, options, prices and the like, or product delays, may have occurred which would not be included in these pages. Your Ford Dealer is your best source for up-to-date information.

