



2006

# MUSTANG





# MUSTANG

THE LEGEND LIVES.

Blue skies, warm sunshine and you – out there cruisin' – in your new Ford Mustang. Coupe or convertible, GT or V6, you can always count on Mustang to help you break free. No meetings to run. No calls to return. No place you'd rather be. The legendary Mustang has been turning heads for over 41 years, having inspired fan clubs on 5 continents, and made appearances in more than 600 motion pictures. Now, get ready to experience the vehicle *Road & Track*\* calls "The best Mustang ever."

\*December 2004.



MUSTANG GT IN VISTA BLUE METALLIC WITH AVAILABLE EQUIPMENT AND MUSTANG GT CONVERTIBLE IN SCREAMING YELLOW



BUILT FOR THE ROAD AHEAD.

## CONTENTS

Pure Power	3
Pony Package	7
Solid Foundation	9
Progressive Technology	11
Interior Details	15
Superior Sound	18
Specifications	23



SQUEALIN' WITH DELIGHT

# POWER MAY BE ADDICTIVE

Every Mustang GT comes equipped with a 4.6L 3-valve V8 engine that serves up a pavement-scorching 300 hp and 320 lb.-ft. of torque. Just how fast can that much power move you? In *Road & Track's*\* testing, "The Mustang GT reaches 60 in just 4.9 sec." The 4.0L V6 engine on Mustang V6 provides a full 210 hp (more than

some previous Mustang GT engines) and 240 lb.-ft. of low-end torque. A standard 5-speed manual gearbox keeps Mustang true to its muscle-car heritage, while a 5-speed automatic is also available. Plus, these engines are more than 50% cleaner\*\* than the previous generation. And just wait 'til you hear 'em growl – truly inspirational.

\*April 2005. \*\*The fleet average of the current Mustang is certified to produce 56% less ozone-forming pollutants than the previous generation.



MUSTANG GT IN WINDVEIL BLUE METALLIC WITH AVAILABLE EQUIPMENT



**RACING**

**PURE POWER**

3



### ROAD-RACING DNA

Track-Proven Technology – For over 40 years now, the legendary Ford Mustang has proven its worth on the racing circuit, and the latest generation is no exception. The Mustang legacy continues with numerous victories in the Grand-Am Cup Series, including a 1st-place finish in its debut race at Daytona International Speedway. A cool performance fact: The production Mustang shares much of its DNA with the race-winning Mustang FR500C. To begin with, the racer's 5.0L "Cammer R50" engine (shown) is a derivative of Mustang GT's 4.6L V8 engine. And aside from its specialized race powertrain, the FR500C actually shares about 80% of its underpinnings and architecture with the Mustang GT. Ladies and gentlemen, start your engines.





MUSTANG V6 DELUXE CONVERTIBLE IN LEGEND LIME METALLIC WITH AVAILABLE EQUIPMENT

WWW.FORDVEHICLES.COM



HIT THE ROAD — PONY STYLE

# FREEDOM TO ROAM

When the open road calls, every Mustang answers with unbridled enthusiasm. To give your Mustang V6 an edge, check out the available new Pony Package. The Anti-lock Brake System with Traction Control steps up performance, while bold new design touches intensify style. An attention-grabbing grille with framed pony emblem and fog lamps,

tri-bar pony fender badges and center caps on the 17" wheels, "Mustang" lower-door tape stripes, and "Mustang" badged front floor mats are all unique to this package. A sporty rear spoiler creates the perfect ending.





MUSTANG V6 PREMIUM IN PERFORMANCE WHITE WITH AVAILABLE PONY PACKAGE

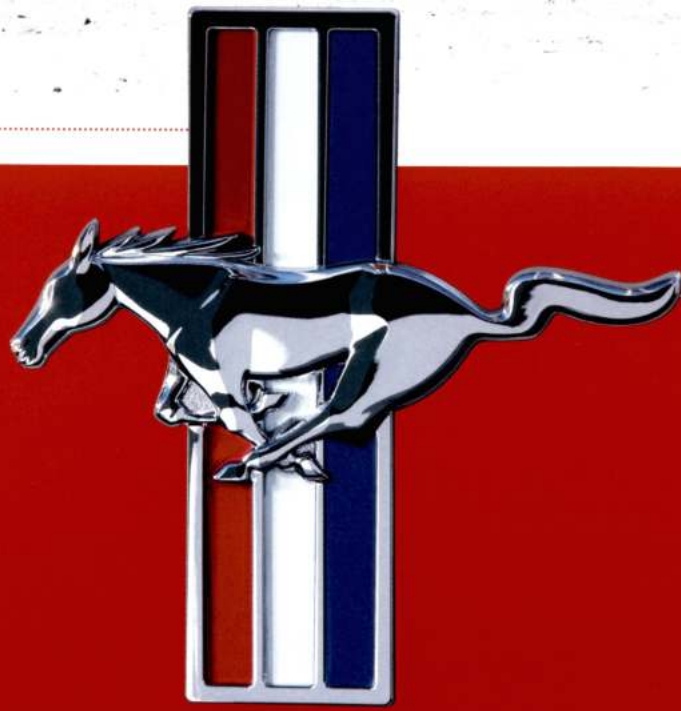

## PONY PACKAGE

7

### STRONG IDENTITY

Classic Tri-Bar Pony Emblem – An instantly recognizable symbol of American muscle and freedom, this inspirational red, white and blue pony design made its debut on the original Mustang over 40 years ago. Today it's featured on the unique front fender badges and wheel center caps of the available Pony Package.

## SERIOUS GRABBING POWER

Big Rotors and Stiff Calipers – With 300 horses under Mustang GT's hood, you need to know you've got what it takes to keep 'em under control. A standard 4-channel Anti-lock Brake System (available on V6 models) enhances the operation of dual-piston aluminum calipers and 12.4" ventilated rotors (11.5" on V6 models) up front, and single-piston calipers with 11.8" ventilated rotors in back. When it comes to brake performance, bigger is definitely better.



## EXCELLENT BALANCE

52/48 Weight Distribution – With a hood that's made of aluminum and a wheelbase that's almost 6" longer than the previous generation, this Mustang's weight distribution is better balanced. On the road, it adds up to mind-blowing acceleration and road-gripping action.

## STRONG BACKBONE

Ultra-Rigid Chassis Structure – From the street to the track, better chassis tuning gives you more robust handling. And the stiffer the chassis, the more precisely we can tune the spring, damping and bushing rates. With its 30% increase in stiffness over the previous generation's chassis, this Mustang's purpose-built, performance-car platform accelerates, turns and stops better than ever before.

## CONFIDENT CONVERTIBLE

Inherent Structural Rigidity – From its very conception, the 2006 Mustang convertible was engineered to convey true solidity with the top down. For example, its body joints and rocker panels were designed to be more rigid than those on the coupe, helping it deliver a remarkably smooth, quiet ride. As *Car and Driver*\* noted, "The result is one of the tightest convertibles on the road."

## 5 ON THE FLOOR

TREMEC 5-Speed Manual Transmissions – True to its muscle-car heritage, Mustang features 5-speed manual gearboxes as standard equipment on V6 and GT models. Shift linkage is geared to provide quick engagement and a solid feel. A 3.55 axle ratio is teamed with the 5-speed manual on Mustang GT for quicker acceleration and improved performance.

\*March 2005.

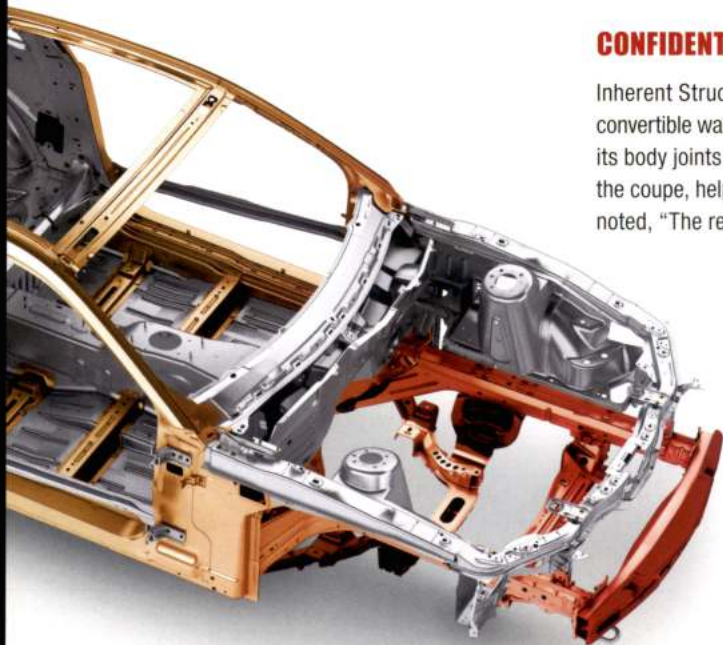

Mustang is meant to run free – around lots of tight corners and down tons of outstanding straightaways. That's why we spent so much time perfecting the underpinnings that drive this legend. Beneath its skin, the 2006 Mustang is packing a carefully crafted performance-car architecture. One that delivers a driving experience like no other. What do we mean? Some of the details are covered below, but you're gonna have to drive it to believe it.

# GEARED TO PERFORM

IN YOUR PURSUIT OF HAPPINESS

## READY TO STRUT

MacPherson Strut Front Suspension – Lightweight for comfort and control, Mustang's MacPherson struts feature concentrically mounted springs in a coil-over-strut configuration to reduce friction and allow more precise shock-valve tuning. Reverse "L" lower control arms are exceptionally strong yet lightweight, while power rack-and-pinion steering gives you excellent response, crisp turn-in and a turning radius that's nearly 3' tighter than the previous generation Mustang. So head for the switchbacks.



## SOLID FOUNDATION

## POWER TO THE PAVEMENT

3-Link, Solid-Axle Rear Suspension – A solid-axle rear suspension helps handle Mustang's brute force and assists in its straight-line dominance. By separating the fore-aft and lateral forces, the rear suspension is tuned to be soft fore-aft for ride comfort and stiff laterally for good handling and steering. A Panhard rod, stabilizer bar (Mustang GT) and 3-link architecture anchor the axle, improving the handling precision and flat-out performance that define this new breed of Mustang.



The 2006 Ford Mustang really flies thanks to advanced technology like its cutting-edge chassis design and the 3-valve V8 under Mustang GT's hood. The newest assembly-line automation brings Mustang's bold sheet metal and body panels together with remarkable precision, while up-to-the-minute safety and security systems help protect you and your passengers out there on the road. And bringing it all to life, both powertrain choices employ the latest technological advancements to deliver on Mustang's performance legend.

# THE LEGEND GOES HI-TECH

REVOLUTIONARY THINKING

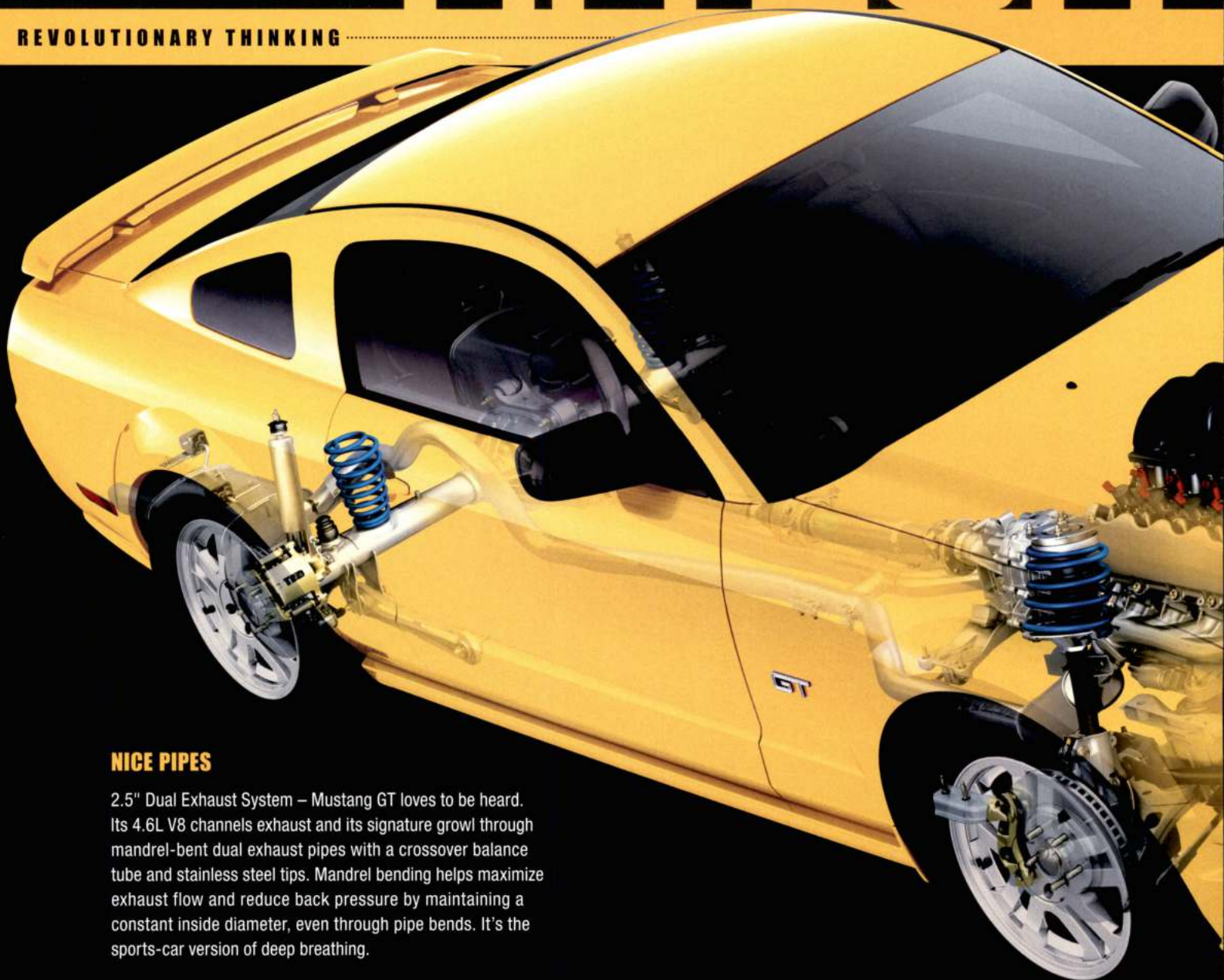

## NICE PIPES

2.5" Dual Exhaust System – Mustang GT loves to be heard. Its 4.6L V8 channels exhaust and its signature growl through mandrel-bent dual exhaust pipes with a crossover balance tube and stainless steel tips. Mandrel bending helps maximize exhaust flow and reduce back pressure by maintaining a constant inside diameter, even through pipe bends. It's the sports-car version of deep breathing.

## DEFENSIVE STRATEGY

**Active Anti-Theft System** – Choose this available system to dramatically enhance the security of your Mustang. It's capable of monitoring the doors, hood, trunk, interior motion and vehicle inclination, or just the doors, hood and trunk, depending on how you set it. For increased acoustic presence, the system includes a separate alarm siren in addition to the vehicle horn and a 60-amp-hour battery that's capable of sounding the alarm longer.

**Personal Safety System®** – Built into every Ford Mustang, this innovative system enhances protection for the driver and front passenger in certain frontal collisions. The system customizes the deployment of the dual-stage front airbags based on several criteria, including the driver's seat position, whether the front safety belts are in use, the amount of pressure exerted on the front-passenger's seat, and the overall severity of the impact.

**Front-Seat Side Airbags** – These available airbags offer an extra margin of head and chest protection for the driver and front passenger. In certain side-impact events, side sensors detect the impact and send a signal to deploy the airbag on the appropriate side of the vehicle.

**Anti-lock Brake System with Traction Control** – These helpful systems are standard on Mustang GT and available on Mustang V6. The Anti-lock Brake System is a 4-channel design that automatically "pumps" the brakes when necessary to help prevent wheel lockup. Mustang's Traction Control allows some rear-wheel slip when accelerating on dry pavement, but if it detects slippery conditions, it acts more aggressively to help the tires maintain grip. And, since it's on a Mustang, Traction Control can be deactivated with the press of a button – any time you want.

## DROP-TOP DESIGN

**Mustang Convertible Soft Top** – The Z-fold design of Mustang's top has a low-profile stance and takes up less space than the previous generation's design when folded down. It features 3-layer construction including a waterproof outer layer, a sound-deadening middle layer and an attractive inner layer. Plus, special sealing helps reduce wind noise and air leaks when the top is up. As *Popular Mechanics* said, "With the top up the Mustang is quieter than it has any right to be."



**PROGRESSIVE TECHNOLOGY**

11



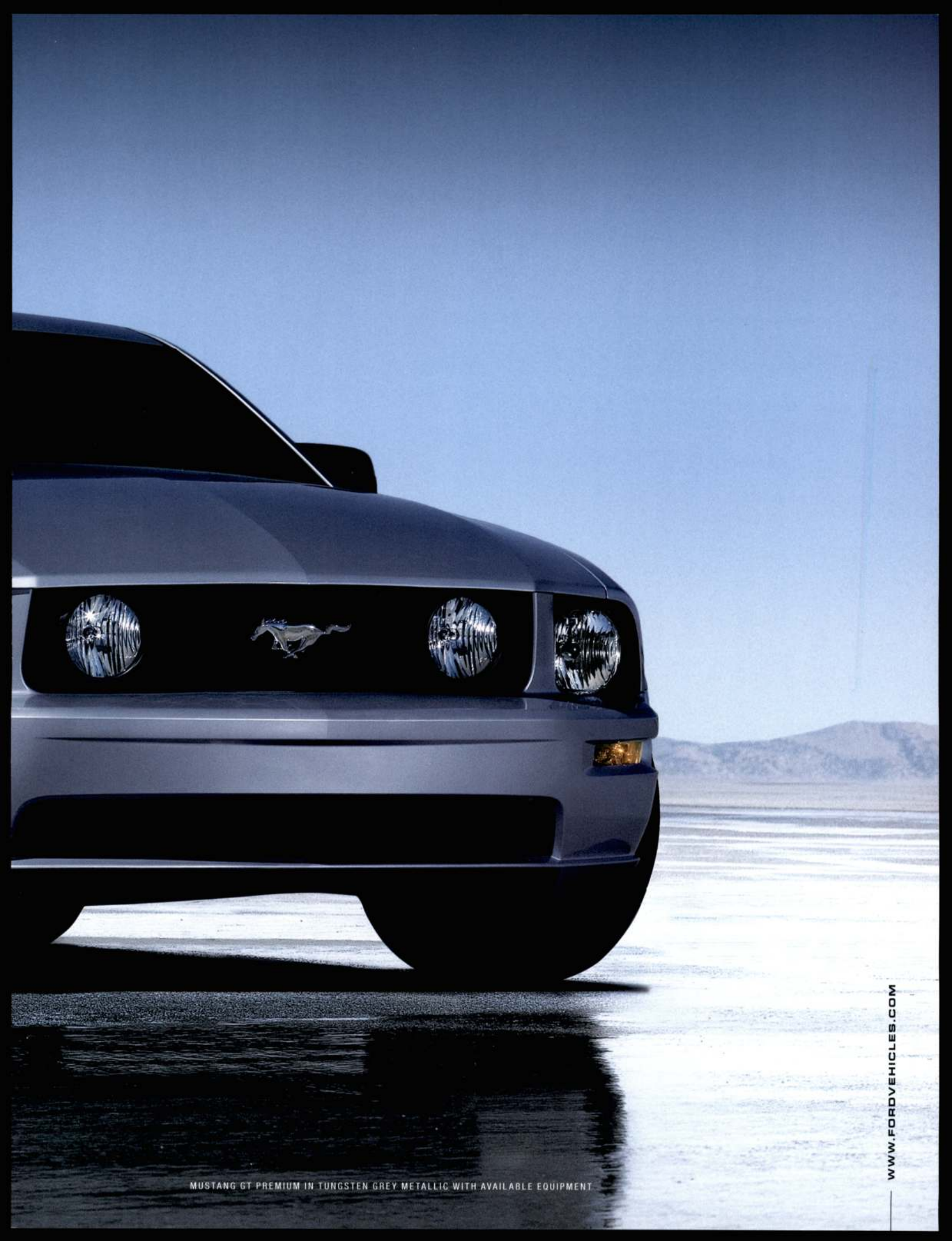

MUSTANG GT PREMIUM IN TUNGSTEN GREY METALLIC WITH AVAILABLE EQUIPMENT

WWW.FORDVEHICLES.COM



# RED HOT

Mustang's sculpted exterior isn't the only surface that turns heads. Inside, you'll find its masterful design, quality materials and precise craftsmanship set new standards in muscle-car style. Always known to be a good value for the times, the 2006 Mustang is no exception. Power door locks with remote keyless illuminated entry, power windows with driver and front-passenger one-touch-up/-down, power sideview mirrors, variable-intermittent windshield wipers, rear-window defroster and speed control are all standard equipment. And thanks to efficient use of interior space, all 4 occupants have the room they need to enjoy the ride – especially the lucky one behind the wheel.



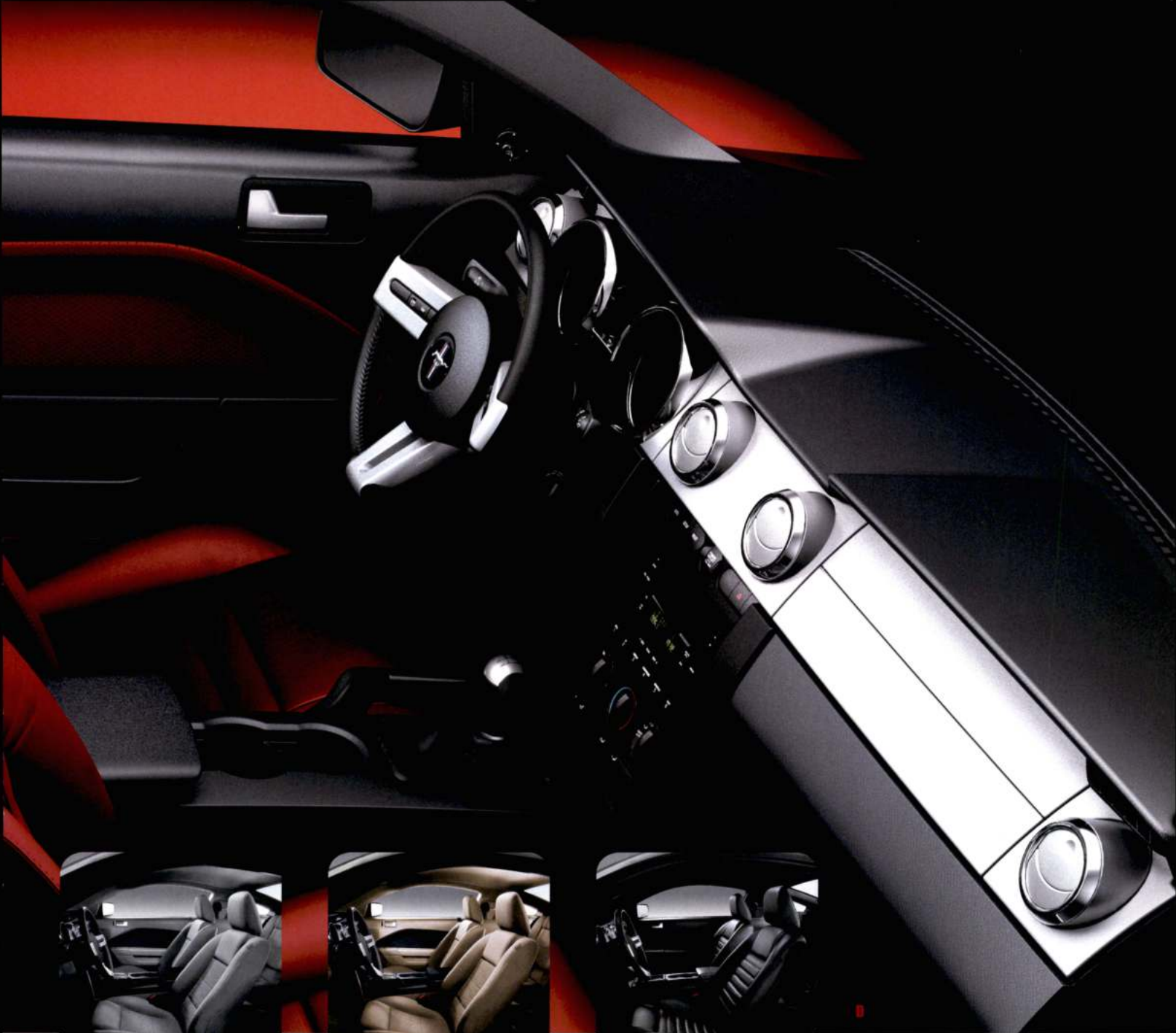

**SEATING OPTIONS**

- A LIGHT GRAPHITE**  
V6 cloth seating shown with Interior Upgrade Package.
- B MEDIUM PARCHMENT**  
V6 cloth seating shown with Interior Upgrade Package.
- C DARK CHARCOAL**  
Mustang GT leather-trimmed seating shown with Interior Upgrade Package.
- D RED ACCENT COLOR**  
V6 leather-trimmed seating shown with Red Interior Accent Package.

**INTERIOR DETAILS**

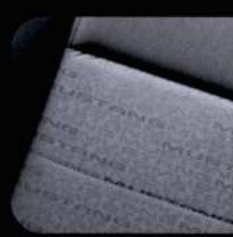

**V6 CLOTH TRIM**  
Mustang Pattern

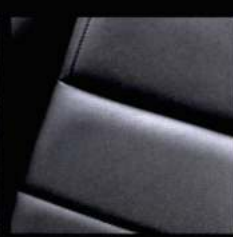

**V6 LEATHER TRIM**



**GT CLOTH TRIM**  
Galloping Horse Pattern



**GT LEATHER TRIM**

Everything in here exudes power, from the chrome-ringed, barrel-like performance gauges to the T-handle on the available automatic tranny or the substantial shift knob on the short-throw 5-speed manual. Even the flush-mounted audio and climate controls have a cool sophistication to them. Slide behind the wheel of a legendary Mustang, and you're instantly inspired to drive – hard and fast – like never before.

# IT'S GOT SERIOUS ATTITUDE

AND YOU CAN MAKE IT MATCH YOURS





## 125 COLORS

MyColor™ – The brightest feature of Mustang's available Interior Upgrade Package is the exclusive MyColor™ instrument panel lighting. Through a special mode in the message center, you can choose from over 100 color combinations to find a hue just right for you – and change it whenever the mood strikes. Feelin' laid back today? Go for a cool blue.



## INTERIOR DETAILS

17

### PUT A SHINE TO IT

Interior Upgrade Package – Features satin-aluminum-finish instrument panel appliqués, door handles, air vents, and scuff plates with bright Mustang lettering, a leather-wrapped steering wheel with satin-aluminum spokes, a satin-aluminum-finish handle for the available automatic, and a 6-gauge instrument cluster with MyColor™ lighting and a message center. The easy way to step it up.

MUSTANG V6 PREMIUM DARK CHARCOAL LEATHER-TRIMMED INTERIOR WITH AVAILABLE EQUIPMENT

Mustang's solid chassis architecture offers benefits beyond improved ride and handling. Its tight structure helps ensure that the sounds in the cabin are the ones you want to hear – like the signature Mustang rumble, or its incredibly powerful Shaker Audio Systems. These available audio systems can actually increase the volume as the vehicle accelerates and decrease it as the vehicle slows, leaving you free to enjoy the ride.

# GET READY TO SHAKE IT UP

CRUISIN' TO THE BEAT

## SOLID STANDARDS

Single-CD Player with 4 Speakers – This standard AM/FM stereo with single-CD player features 160 watts of power. And Mustang's electrical hardware allows the system to continue playing for a bit after the ignition key is removed.



## POWERFUL PERFORMANCE

Shaker 500 Audio System – With the ability to play standard and MP3-burned CDs on its 6-disc in-dash CD changer, you could listen to 1200 songs in a row or about 40 hours of continuous music. Who knows where you'd end up? The system's 8 speakers, including 2 door-mounted subwoofers, blast out up to 500 watts of peak power. Standard on Premium and available on all other models.



## SOUNDS THE ALARMS

Shaker 1000 Audio System with 4 Subwoofers – 1000 watts of peak power. A 6-disc in-dash CD changer that plays standard and MP3-burned CDs. And 10 premium Audiophile® speakers, including 4 subwoofers (2 door-mounted and dual 500-watt subwoofers in the trunk) for seriously thumpin' bass. Let 'em know you're comin' with the ultimate sound system for the ultimate ride. Shown above at left, it's available on Mustang V6 Premium and Mustang GT models.

## TAKE NOTE

Mustang Exhaust Rumble – Before a single V8 was built, the sweet rumble released from Mustang GT's dual-exhaust pipes was perfected on computers and in the Ford listening lab with vehicle prototypes. As *Road & Track*\* said of the convertible, "Top down, it's all the better to hear the V8's throaty song..." You'll notice it's tuned to reach your ears in the right doses, at the right times, such as during acceleration. At cruising speeds, the sound fades away to allow the audio system to fill the cabin.

\*March 2005.

# LET YOUR MUSTANG GO WILD WITH GENUINE FORD ACCESSORIES



**FRONT END COVER**

**RACING STRIPES**

**ELECTROCHROMIC MIRROR WITH HOMELINK®**

**REAR SPOILER**

**18" CUSTOM WHEELS**



**ALL-WEATHER FLOOR MATS**



**REMOTE START SYSTEMS**



**SPLASH GUARDS**



**FULL VEHICLE COVER**



**18" CUSTOM WHEELS**



**WHEEL LOCKS**

There's a whole catalog of great choices to help you personalize your new Mustang, and it's available at your Ford Dealer today. Engineered by Ford for excellent fit and long-wearing durability, Genuine Ford Accessories empower your Mustang with comfort, convenience and cool. And if installed by your Ford Dealer at time of vehicle purchase, they're backed by a 3-year/36,000-mile limited warranty.\* Pick up your Genuine Ford Accessories catalog today or view it online at [www.fordvehicles.com](http://www.fordvehicles.com).

\*See your dealer for Limited Warranty details.



[fordaccessoriesstore.com](http://fordaccessoriesstore.com)

**“COOL FACTOR:  
A PERFECT  
MOTOR TREND  
JANUARY 2005  
10!”**

**“BEST MUSCLE CAR”**

**CAR AND DRIVER'S 10BEST FOR 2005  
FORD MUSTANG GT  
JANUARY 2005**





MUSTANG GT IN REDFIRE METALLIC WITH AVAILABLE EQUIPMENT

WWW.FORDVEHICLES.COM

# SPECIFICATIONS

## MODEL HIGHLIGHTS



### MUSTANG V6

#### STANDARD

4.0L SOHC V6 Engine  
5-Speed Manual Transmission  
Stainless Steel Single Exhaust  
Power 4-Wheel Disc Brakes  
Front Stabilizer Bar  
4-Way Manual Height-Adjustable Driver's Seat  
50/50 Split-Folding Rear Seat  
Tilt Steering Wheel  
Speed Control  
Power Windows and Door Locks  
Remote Keyless Illuminated Entry  
Air Conditioning  
AM/FM Single-CD Audio System  
16" Steel Wheels with Wheel Covers  
P215/65R16 All-Season Tires

#### DELUXE

(in addition to Standard)

16" Bright Machined-Aluminum Wheels

#### PREMIUM

(in addition to Deluxe)

Shaker 500 Audio System with 6-Disc In-Dash CD Changer, 8 Speakers and MP3 Capability  
6-Way Power Driver's Seat with Power Lumbar  
16" Bright Machined-Aluminum Wheels with Chrome Spinners

### MUSTANG GT

#### DELUXE

4.6L 3-Valve V8 Engine  
5-Speed Manual GT Transmission  
Stainless Steel Dual Exhaust  
Power 4-Wheel Disc Anti-Lock Brakes  
Front and Rear Stabilizer Bars  
Traction Control  
Fog Lamps  
Rear Spoiler

6-Way Power Driver's Seat with Power Lumbar

50/50 Split-Folding Rear Seat  
Tilt Steering Wheel  
Speed Control

Power Windows and Door Locks  
Remote Keyless Illuminated Entry  
Air Conditioning

AM/FM Single-CD Audio System

17" Painted-Aluminum Wheels  
P235/55ZR17 Performance Tires

#### PREMIUM

(in addition to Deluxe)

Shaker 500 Audio System with 6-Disc In-Dash CD Changer, 8 Speakers and MP3 Capability  
Leather-Trimmed Sport Bucket Seats

### STANDARD INTERIOR



### INTERIOR SPORT APPEARANCE PACKAGE



### INTERIOR UPGRADE PACKAGE



## WHEELS



16" Steel Wheel with Wheel Cover  
Standard on V6 Standard



16" Bright Machined-Aluminum Wheel  
Standard on V6 Deluxe



16" Bright Machined-Aluminum Wheel with Chrome Spinner  
Standard on V6 Premium; Available on V6 Deluxe



17" Painted-Aluminum Wheel with Tri-Bar Pony Center Cap  
Available with Pony Package



17" Painted-Aluminum Wheel  
Standard on GT



17" Bright Machined-Aluminum Wheel with Tri-Bar Pony Center Cap  
Available on GT



18" Premium Aluminum Wheel with Tri-Bar Pony Center Cap  
Available on GT



18" Polished-Aluminum Wheel with Tri-Bar Pony Center Cap  
Late availability on GT



## STANDARD FEATURES

### MECHANICAL

100,000-mile tune-up interval\*  
 Compact spare tire  
 Power 4-wheel disc brakes  
 Power rack-and-pinion steering  
 Rear-wheel drive  
 Stabilizer bars – Front on V6, front and rear on GT  
 Suspension – Front: coil-over-strut with reverse "L" lower control arms; rear: coil spring 3-link solid axle with Panhard rod and outboard-mounted shocks

### SAFETY/SECURITY

Personal Safety System® for driver and front passenger – With dual-stage front airbags.\*\* safety belt pretensioners, driver's seat position sensor, crash severity sensor, energy-management retractors, safety belt usage sensors and Front-Passenger Sensing System  
 Belt-Minder® safety belt reminder  
 LATCH – Lower anchors and tether anchors for child-safety seats  
 Remote keyless illuminated entry system  
 Safety belts – 3-point for all seating positions  
 Side-intrusion door beams

### SEATING

4-way manual height-adjustable driver's seat  
 Front cloth bucket seats  
 Rear 50/50 split-folding cloth seat

### INTERIOR

Air conditioning  
 Carpeted front floor mats  
 Chrome-ringed 4-gauge instrument cluster and air vents  
 Cupholders – 2  
 Driver's footrest  
 Front-door map pockets  
 Full center console with armrest and storage  
 Power door locks  
 Power points – 2  
 Power windows with front one-touch-up/-down feature  
 Steering wheel-mounted speed control  
 Tilt steering wheel

### EXTERIOR

Power sideview mirrors  
 Rear-window defroster  
 Variable-intermittent windshield wipers

## ENGINES

	4.0L SOHC V6	4.6L 3-VALVE V8
Horsepower (hp @ rpm)	210 @ 5300	300 @ 5750
Torque (lb.-ft. @ rpm)	240 @ 3500	320 @ 4500

## EPA-ESTIMATED FUEL ECONOMY

	4.0L SOHC V6	4.6L 3-VALVE V8
Manual transmission	19 city/28 hwy.	17 city/25 hwy.
Automatic transmission	19 city/25 hwy.	18 city/23 hwy.

\*Under normal driving conditions with routine fluid and filter changes.

\*\*Always wear your safety belt and secure children in the rear seat.

\*Not available when Medium Parchment interior is combined with Satin Silver Metallic exterior.

Audiophile is a registered trademark of Audiophile, Inc.

## FEATURES & OPTIONS

### V6 STANDARD

### V6 DELUXE

### V6 PREMIUM

### GT DELUXE

### GT PREMIUM

### MECHANICAL

●	●	●	—	—	4.0L SOHC V6 engine
—	—	—	●	●	4.6L SOHC 3-valve V8 engine
●	●	●	—	—	5-speed manual transmission (3.31 axle ratio)
—	—	—	●	●	5-speed manual GT transmission (3.55 axle ratio)
○	○	○	○	○	5-speed automatic transmission (3.31 axle ratio)
—	—	—	●	○	Limited-slip differential (optional on GT with automatic transmission)
●	—	—	—	—	16" steel wheels with wheel covers
—	●	—	—	—	16" bright machined-aluminum wheels
—	○	—	—	—	16" bright machined-aluminum wheels with chrome spinners
—	—	—	●	●	17" painted-aluminum wheels
—	—	—	○	○	17" bright machined-aluminum wheels (split-spoke)
—	—	—	○	○	18" premium aluminum wheels
—	—	—	○	○	18" polished-aluminum wheels (late availability)
●	●	●	—	—	P215/65R16 all-season tires
—	—	—	●	●	P235/55ZR17 all-season performance tires
—	—	—	○	○	P235/50ZR18 performance tires
○	○	○	●	●	Anti-lock Brake System (ABS) and Traction Control
●	●	●	—	—	Stainless steel single exhaust
—	—	—	●	●	Stainless steel dual exhaust with bright tips

### SAFETY/SECURITY

○	○	○	○	○	Active Anti-Theft System
—	○	○	○	○	Front-seat side airbags (requires Interior Upgrade Package)
—	○	○	○	○	Wheel-lock kit

### SEATING

—	○	●	●	●	6-way power driver's seat with power lumbar
—	—	○	—	—	Leather-trimmed bucket seats
—	○	○	○	●	Leather-trimmed sport bucket seats (V6 requires Red Interior Accent Package)

### INTERIOR

●	●	—	●	—	AM/FM audio system with single-CD player and 4 speakers (160-watt)
○	○	●	○	●	Shaker 500 Audio System with AM/FM stereo, 6-disc in-dash CD changer, 8 speakers and MP3 capability (500-watt)
—	—	○	○	○	Shaker 1000 Audio System with AM/FM stereo, 6-disc in-dash CD changer, 10 Audiophile® speakers and MP3 capability (1000-watt)

### EXTERIOR

○	○	○	○	○	Convertible soft boot
—	—	—	●	●	Fog lamps
—	—	—	●	●	Rear spoiler
—	—	—	○	○	Spoiler delete option

### PACKAGES

—	○	○	—	—	Exterior Sport Appearance Package <sup>1</sup> – Includes rear spoiler and lower-bodyside Mustang logo tape stripe
—	○	○	○	○	Interior Sport Appearance Package – Includes leather-wrapped steering wheel with satin-aluminum spokes and satin-aluminum-plated shift lever (automatic) or bright shift knob (manual)
—	○	○	○	○	Interior Upgrade Package – Includes 6-gauge instrument cluster with MyColor™ illumination; leather-wrapped steering wheel with satin-aluminum spokes; satin-aluminum-finish instrument panel, air vents, door handles and scuff plates; message center; and Dark Charcoal door-panel inserts
—	—	○	—	—	Pony Package <sup>1</sup> – Pony grille and fog lamps, rear spoiler, chromed air vent surrounds, 17" painted-aluminum wheels with tri-bar Pony center caps, Pony fender badges, lower bodyside Mustang logo tape stripe, carpeted floor mats with brushed-chrome MUSTANG badge, anti-lock brakes, and Traction Control
—	○	○	○	○	Red Interior Accent Package – Red leather-trimmed sport bucket seats, Red door-panel inserts and Red floor mats (requires Interior Upgrade Package and Dark Charcoal interior trim)
—	○	○	—	—	Tape Stripe Delete Option (Exterior Sport and Pony Packages)

● Standard ○ Optional — Not Available

# SPECIFICATIONS

## INTERIOR COLORS

### V6 TRIM



Medium Parchment Mustang Cloth  
Standard on V6



Light Graphite Mustang Cloth  
Standard on V6



Dark Charcoal Mustang Cloth  
Standard on V6



Medium Parchment Leather  
Available on V6



Light Graphite Leather  
Available on V6



Dark Charcoal Leather  
Available on V6

### GT TRIM



Medium Parchment Galloping Horse Cloth  
Standard on GT



Light Graphite Galloping Horse Cloth  
Standard on GT



Dark Charcoal Galloping Horse Cloth  
Standard on GT



Medium Parchment Leather  
Available on GT



Light Graphite Leather  
Available on GT



Dark Charcoal Leather  
Available on GT

### RED INTERIOR ACCENT PACKAGE



Red Leather Trim  
Available on V6 Deluxe and  
Premium and GT

### MEDIUM PARCHMENT

### LIGHT GRAPHITE

### DARK CHARCOAL

### RED INTERIOR ACCENT PACKAGE

### ALL MODELS

- Performance White
- Screaming Yellow
- Torch Red
- Redfire Metallic
- Legend Lime Metallic
- Windveil Blue Metallic
- Vista Blue Metallic
- Satin Silver Metallic
- Tungsten Grey Metallic
- Black

### AVAILABLE CONVERTIBLE TOP COLORS

- Parchment
- Black\*

\*Black top not available when Medium Parchment interior is combined with Vista Blue Metallic exterior.

## TAPE STRIPE COLORS

### EXTERIOR SPORT APPEARANCE PACKAGE



Black



White



Pearl Gold

### PONY PACKAGE



Black



White



Pearl Gold

Please see your Ford Dealer for tape stripe availability details.

## EXTERIOR COLORS



Performance White



Screaming Yellow



Torch Red



Redfire Metallic



Legend Lime Metallic



Windveil Blue Metallic



Vista Blue Metallic



Satin Silver Metallic



Tungsten Grey Metallic



Black

## CONVERTIBLE TOP COLORS



Parchment



Black

Ford uses clearcoat paint for beauty and protection. Colors shown are representative only. See your dealer for actual paint/trim options. Vehicles shown may contain optional equipment.

### New-Vehicle Limited Warranty

We want your Ford Mustang ownership experience to be the best it can be. So under this warranty, your new vehicle comes with 3-year/36,000-mile Bumper-to-Bumper Coverage, 5-year/50,000-mile Safety Restraint Coverage, and 5-year/unlimited-mile Corrosion (Perforation) Coverage – all with no deductible. Please ask your Ford Dealer for a copy of this limited warranty.



Get the ride you want. Whether you plan to lease or finance, you'll find the choices that are right for you at Ford Credit. Ask your Ford Dealer for details or check us out at [www.fordcredit.com](http://www.fordcredit.com).



Choose the insurance program that's designed for your vehicle – Ford Motor Company Insurance Services. Our program helps you receive the rates and service you deserve. Call 1-877-367-3847 or visit us at [www.fordvip.com](http://www.fordvip.com) for a no-obligation quote. Insurance offered by American Road Services Company (in CA, American Road Insurance Agency), a licensed agency and subsidiary of Ford Motor Company.



For a purchase or lease, the Ford **Extended Service Plan (ESP)** gives you "Peace-of-Mind" protection designed to cover key vehicle components and protect you from the cost of unexpected repairs. Ask your dealer for an ESP backed by Ford Motor Company and honored at all Ford dealerships.

# 2006 FORD MUSTANG

## JOIN THE CLUB.

**NATIONAL** International Mustang Bullitt Owners Club • Mustang Club of America • Mustang SVO Owners Association, Inc. • Shelby American Automobile Club • SVT Cobra Owners Association • SVT Owners Association • Yellow Mustang Registry **ALABAMA** Heart of Dixie Mustang Club • Magic City Mustangs • Rocket City Mustang Club **ARIZONA** Old Pueblo Mustang Club • Southern Arizona Mustang Club **CALIFORNIA** All Mustang & Ford Club of Southern California • Beach Cities Mustang Club • Cobra Owners Club of Orange County • Golden Hills Mustang Club • Mustang Owners Club of California • Northern California Region SAAC • South Bay Mustang Owners **COLORADO** SAAC Colorado Region • The Early Mustang Club of Colorado **DELAWARE** First State Mustang & Ford Club • The Lower Delaware Mustang Club **FLORIDA** Classic Mustangs of Tampa • Fort Lauderdale Mustang Club • Gulfshore Mustang Club • Imperial Mustangs of Polk County • Mid-Florida Mustang Club • Mustang Club of West Central Florida **GEORGIA** Central Savannah River Area Mustang Club • Georgia Regional Mustang Club **IDAHO** Treasure Valley Mustangs & Fords Club **ILLINOIS** Central Illinois Mustangers **INDIANA** Falls City Mustang Club • Indiana SAAC • Michiana Mustangs • Southside Mustang Club **KANSAS** Vintage Mustang Club of Kansas City **KENTUCKY** Bluegrass Mustang Club • Derby City Mustang Club • The Mustang Mafia • **STAMPEDE** Mustang/SVT Club **LOUISIANA** Baton Rouge Mustangers **MAINE** Southern Maine Mustang Club **MARYLAND** SAAC Group of Maryland **MASSACHUSETTS** Mustang Car Club of New England **MICHIGAN** Mustang Club of Mid-Michigan • Mustang Owners Club of Southeastern Michigan • SAAC Motor City Region • West Michigan Mustang Club **MINNESOTA** Upper Midwest Region SAAC **MISSOURI** Central Missouri Mustang Club • Mid-America Mustangers • Show-Me Mustang Club **NEBRASKA** Capitol City Ford Club **NEW HAMPSHIRE** New Hampshire Mustang Club **NEW JERSEY** Central Jersey Mustangs and Fords Club • Garden State Regional Mustang Club • SAAC New Jersey Region • South Jersey Mustang Club **NEW YORK** Adirondack Shelby Mustang Club • Classic Mustang Group – Long Island • Crossbay Cruisers Mustang Club of NYC, Ltd. **NORTH CAROLINA** 2005 Mustang Enthusiasts Car Association • Carolina Regional Mustang Club • Chrome Pony Mustang Club • Southeastern North Carolina Regional Mustang Club **OHIO** Mahoning Valley Mustangs • Mustang Club of Ohio • Tri-State Mustang Club **OKLAHOMA** Mid-America Shelby Club • Oklahoma Mustang Club **OREGON** Mustang Wranglers of Oregon • SAAC Northwest Region **PENNSYLVANIA** Greater Pittsburgh Mustang Club • Lehigh Valley Region SAAC • Valley Forge Mustang Club **SOUTH CAROLINA** Low Country Mustang Club **SOUTH DAKOTA** Rapid Mustang Club of the Black Hills **TENNESSEE** First Tennessee Regional Group • Tennessee Valley Mustang Club **TEXAS** Lubbock Mustang Club • Mustang Club of Houston • Mustang Owners Club of Austin • Mustangs of East Texas • North Texas Mustang Club **VIRGINIA** Central Virginia Mustang Club • National Capital Region Mustang Club • Roanoke Valley Mustang Club • Styling Stangs of Hampton Road • Victory 7 Mustang Club **WASHINGTON** Mustangs West • Pierce County Mustang Club **WISCONSIN** Wisconsin Early Mustangers **ICELAND** The Icelandic Mustang Club **QUÉBEC** Montréal Mustang (1994) Inc. **UNITED KINGDOM** Mustang Owners Club of Great Britain

(and that's just to name a few)

For more information, go to [www.fordvehicles.com](http://www.fordvehicles.com)



BUILT FOR THE ROAD AHEAD.

© 2005 Ford Motor Company. 66MSTCAT  
Litho in USA on recycled paper (20% post consumer)